

IV CORE UPGRADE KIT

MAN0016-V2



YOUR IV CORE KIT INCLUDES:

- 1 x Propshaft Assembly
- 1 x ST All-Metal Bolt
- 1 x ST3 Soft Tip Bolt
- 1 x Spares Bag

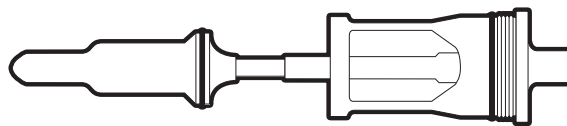
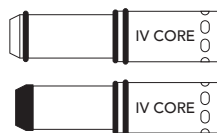
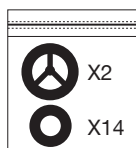

The **GEO IV Core** is designed to fit and work in GEO, GEO+, SL91, GEO2, GEO2.1, GEO3 and GEO3.1 markers.

Please fully read these instructions before attempting to install this **IV Core** kit into your marker.

IMPORTANT!



The IV Core kit includes two bolts. An all-metal construction bolt and a bolt that has a soft tip attached. We do NOT recommend that the soft tip bolt is used on any GEO prior to the GEO3. That is, we do NOT recommend that the soft tip bolt is used on: GEO, GEO+, SL91, GEO2, GEO2.1.

Using the soft tip bolt in a GEO prior to the GEO3 may result in the soft tip becoming dislodged either during use or whilst sat gassed up. This is due to the design differences between the GEO3 Can and everything previous to this. The Can for the GEO3 onwards is designed specifically for use with soft tip bolts. They are designed to prevent any pressure build-up between the internal 017NBR70 o-ring of the Can and the back of the soft tip, which can lead to the soft tip being blown off the head of the bolt.

FITTING THE IV CORE

IMPORTANT!



The IV Core kit is designed to replace the Propshaft assembly and Bolt of your GEO. You **MUST** use the existing Can from your chosen donor marker.

- 1 Remove the original Propshaft Assembly, Bolt and Can.
- 2 Separate the Can and Bolt assembly.
- 3 Place the original Bolt and Propshaft assembly to one side. This will no longer be required.
- 4 Take your Can and clean it thoroughly. Pay particular attention to the internal 017NBR70 o-ring. In the IV Core kit you will find a spares bag. Remove and replace the external 020NBR70 and internal 017NBR70 o-ring if required.

- 5 Grease the Can as per the instructions in your GEO manual. We only recommend the use of Planet Eclipse grease in the GEO internal assembly.
- 6 Grease whichever new IV Core Bolt you are choosing to install at this time as per the instructions in your GEO manual. Ensure you grease both the inside and outside of the bolt. Insert the IV Core Bolt into your existing Can.
- 7 Grease the front 14x2NBR70 Propshaft o-ring of your new IV Core Propshaft Assembly as per the instructions in your GEO manual. Insert the IV Core Propshaft Assembly into back of the IV Core bolt.
- 8 Insert the whole assembly into the back of your GEO. Screw in finger-tight. Your new IV Core kit is installed and ready to use.

IMPORTANT!



Your GEO **MUST** be chronographed before use!!

PROPSHAFT CUT OFF ADJUSTMENT

The GEO IV Core Kit has a feature that allows adjustment of the shut-off point of the Propshaft. This shut-off dictates how much tail-end air is trapped in the firing chamber after each shot. The more air that is trapped, the more efficient the marker becomes. The less air trapped, the less efficient the marker becomes. However, if too much air is trapped in the firing chamber after each shot, peak velocity will not be achieved.

The adjuster screw can be found in the rear of the back cap. It uses a 1/8" Hex Key for adjustment.

For reference the adjuster has a range of 8 full turns. Always use the adjusters **FULLY REARWARD** position as a starting point. Screw the adjuster counter-clockwise until the screw is flush with the rear of the back cap. **DO NOT** over-tighten. At this point the Cut Off is set at the minimum level. This is trapping the least amount of air after each shot. **NOTE:** Even in this position the IV Core is still trapping over 25psi per shot inside the firing chamber.

From the factory the IV Core kit comes with the Cut Off adjuster set at a mid-point (4 turns) that will return excellent efficiency. There should never be a need to adjust the Cut Off Adjustment screw.

Screwing the adjuster inwards (Clockwise) will increase the amount of trapped air. **DO NOT** screw in the adjuster past 8 full turns from the fully rearward position. **NOTE:** Screwing the adjuster further in than the factory setting of 4 turns may cause a reduction in velocity.

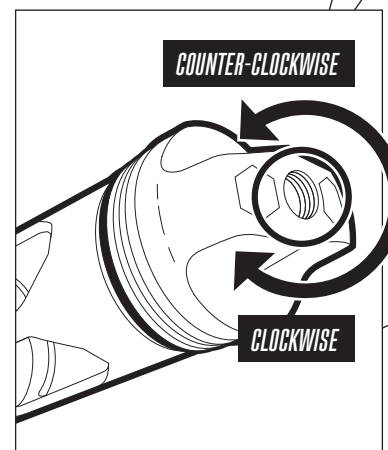

IV CORE UPGRADE KIT

MAN0016-V2



IMPORTANT!



Your GEO MUST be chronographed before use!!

ADVANCED IV CORE INFORMATION:

The IV Core Bolt and Can can be maintained in exactly the same way the Can and Bolt depicted in your GEO User Manual.

However, the Propshaft may require some further maintenance that is not covered in your User Manual.

ADVANCED BOLT SYSTEM MAINTENANCE

This procedure is only required if you are maintaining the rear section of the propshaft assembly due to a leak coming from the front of the bolt. After maintaining the front 14x2 propshaft o-ring and 017 internal can o-ring.

Firstly remove the bolt system assembly, then separate the bolt can and propshaft assemblies as detailed on pages 48-49 of the GEO 3.5 manual.

Go to planetecclipse.com for the latest versions of our manuals and instructions, for reference.

Push down on the split in the delrin retaining ring and pull the retaining ring out of the propshaft back cap (*see figure 20A*).

Remove the propshaft from the back cap, taking care not to lose the propshaft spring, plunger or plunger o-ring.

Check the 14x2 o-ring at the back of the propshaft, and clean or replace then re-lubricate with Eclipse Grease as necessary. Check the rear bumper for signs of wear, replace as necessary (*see figure 20B*).

Place the spring within the propshaft (*see figure 20C*).

Replace the back cap over the rear of the propshaft, pushing the propshaft back into the back cap (*see figure 20D*)¹.

Compress the retaining ring (*see figure 20E*) and push the retaining ring into the back cap. The retaining ring needs to sit in its designated groove in the back cap. If the propshaft can be pulled out of the back cap then the retaining ring has not seated correctly.

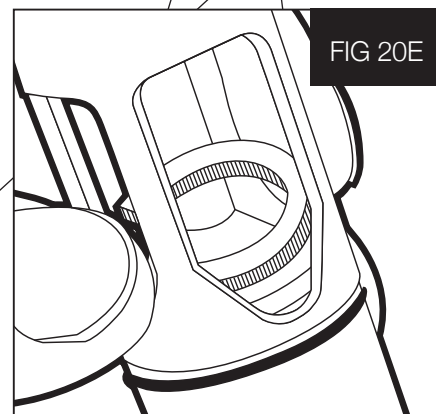
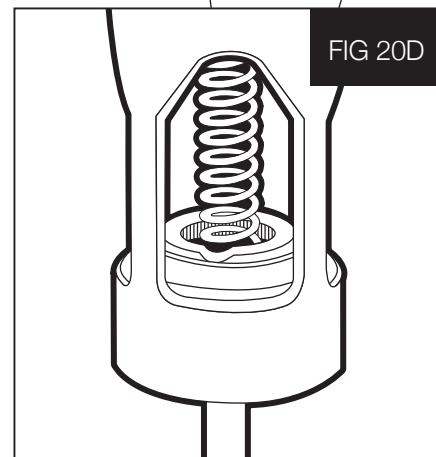
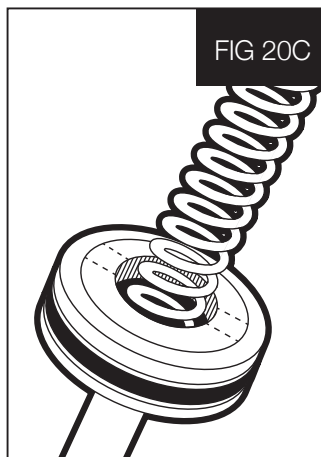
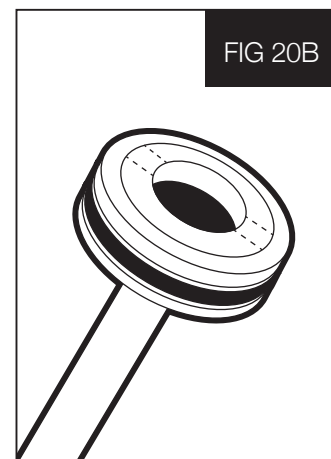
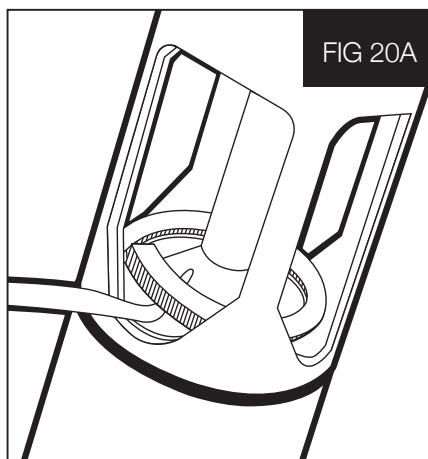

WARNING!



Always de-gas your marker, discharging any stored gas in a safe direction, and remove the barrel, loader, air system and any paintballs to make the marker easier and safer to work on.

¹ If any o-rings or the bumper are damaged then replace them. Extra o-rings and bumpers are available in parts kits available at www.planetecclipse.com.