

protoyz
PLAYING GEAR

protoyz
SPEEDSTER

EN: WARNING!

INSTALLATION OF ANY PARTS OR MAINTENANCE OF YOUR MARKER SHOULD BE CARRIED OUT BY A PROFESSIONAL AIR-SMITH. DE-GAS YOUR MARKER, DISCHARGING ANY STORED GAS IN A SAFE DIRECTION, AND REMOVE THE BARREL, LOADER, AIR SYSTEM AND ANY PAINTBALLS TO MAKE THE MARKER EASIER AND SAFER TO WORK ON.

ES: ¡PELIGRO!

LA INSTALACIÓN DE CUALQUIER PIEZA O EL MANTENIMIENTO DE SU MARCADORA DEBE SER REALIZADA POR UN PROFESIONAL TÉCNICO. DESPRESURICE SU MARCADORA, DESCARGUE CUALQUIER GAS ALMACENADO EN UNA DIRECCIÓN SEGURA Y RETIRE EL CAÑÓN, CARGADOR, SISTEMA DE AIRE Y CUALQUIER BOLA DE PINTURA PARA HACER QUE LA MARCADORA SEA MÁS FÁCIL Y SEGURA PARA TRABAJAR.

DE: WARNUNG!

JEGLICHE DE- BZW. INSTALLATION VON MARKIERER-KOMPONENTEN SOWIE DIE WARTUNG SOLLTEN NUR VON FACHPERSONAL DURCHFÜHRT WERDEN. HALTE DICH AN DIE FOLGENDEN SCHRITTE UM AN DEINEM MARKIERER EINFACH UND VOR ALLEN DINGEN SICHER ARBEITEN ZU KÖNNEN. LASS JEGLICHE LUFT AUS DEM MARKIERER ENTWEICHEN UND VERGEWISSERE DICH, DAS KEINE WEITERE LUFT IM DIESEM GESPEICHERT IST. ERST DANN ENTFERNST DU DAS LAUFSYSTEM, DEN HOPPER SOWIE ALLE IM MARKIERER BEFINDLICHEN PAINTBALLS UND DAS DRUCKLUFTSYSTEM.

FR: ATTENTION!

TOUTE MODIFICATION OU RÉPARATION DOIT ÊTRE EFFECTUÉE PAR UN PROFESSIONNEL QUALIFIÉ. POUR TRAVAILLER EN TOUTE SÉCURITÉ SUR VOTRE LANCEUR, RETIRER VOTRE BOUTEILLE, ÉVACUER LE GAZ RÉSIDUEL, RETIRER LE CANON, LE RÉSERVOIR DE BILLE ET TOUTES LES BILLES.



GETTING STARTED WITH THE PROTOYZ SPEEDSTER LOADER

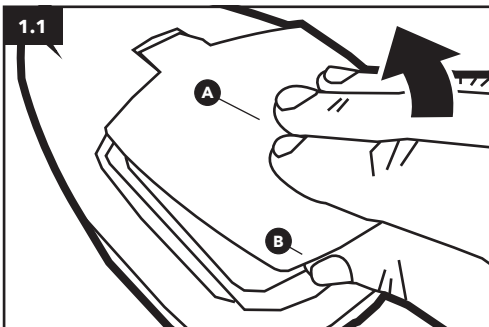

INSTALLING THE BATTERIES.

1.1 - WITH YOUR FINGERTIPS ON THE TOP-CENTRE OF THE LID (A) USE YOUR THUMB BENEATH THE REAR LIP (B) TO PULL AND LEVER THE LID OPEN.

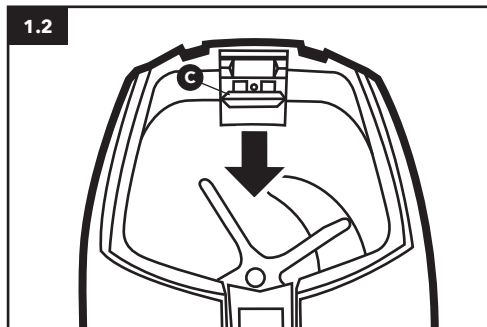

1.2 - PUSH THE UPPER SHELL LOCK (C) DOWN TO RELEASE THE SHELL HALVES.
NOTE: THE SPEEDSTER CAN STILL OPERATE WITH THE UPPER SHELL LOCK RELEASED SO CHECK ITS POSITION BEFOREHAND.

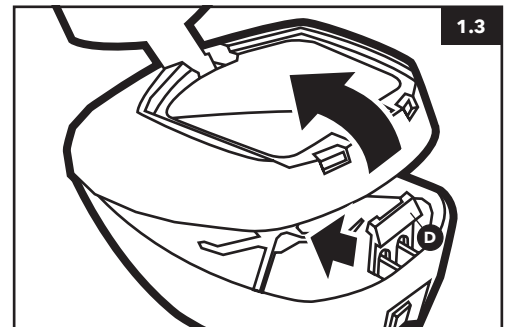

1.3 - PUSH (D) FORWARDS AND PIVOT THE UPPER SHELL UPWARDS AND FORWARDS TO REMOVE FROM THE LOWER SHELL.

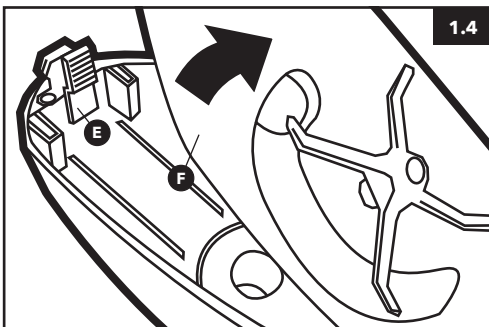

1.4 - PUSH THE TRAY LATCH (E) AND PIVOT THE TRAY (F) UPWARDS AND BACKWARDS TO REMOVE, GIVING YOU ACCESS TO THE BATTERY MODULE AND THE DRIVETRAIN OF THE SPEEDSTER LOADER.

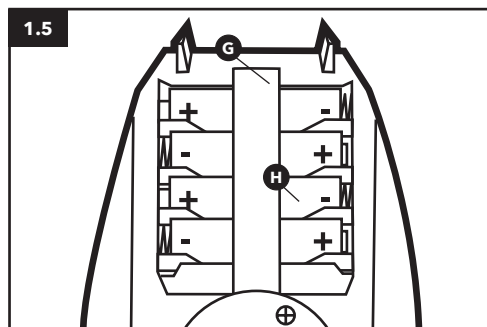

1.5 - UNDO THE BATTERY MODULE STRAP (G) AND INSERT 4 X AA BATTERIES AS PER THE ORIENTATION SHOWN IN THE BATTERY MODULE SLOTS (H).

SEE 4.1 FOR LOADER REASSEMBLY.

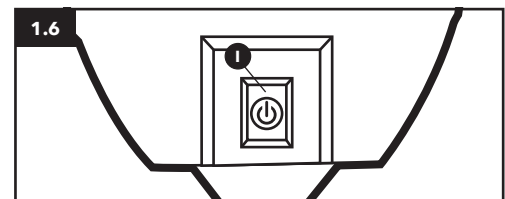

SWITCHING THE SPEEDSTER ON/OFF.

1.6 - PUSH THE ON/BUTTON BUTTON (I) TO SWITCH THE SPEEDSTER ON/OFF. THIS WILL STEADILY FLASH GREEN WHEN IT IS ON.

LOW BATTERY LEVEL INDICATOR.

THE ON/OFF BUTTON WILL FLASH FASTER THAN NORMAL AND THE SPEEDSTER WILL SLOW DOWN. REPLACE BATTERIES WHEN THE SPEEDSTER NO LONGER FEEDS AT THE REQUIRED RATE.



NOTE: STORE IN A COOL, DRY PLACE OUT OF DIRECT SUNLIGHT. LONG TERM EXPOSURE TO DIRECT SUNLIGHT, CHEMICALS AND LARGE TEMPERATURE FLUCTUATIONS MAY DAMAGE THE LOADER.

TAKE CARE NOT TO DAMAGE THE EXPOSED COMPONENTS UNDERNEATH THE TRAY, ESPECIALLY THE CIRCUIT BOARD.



© ALL RIGHTS RESERVED
DISTRIBUTED UNDER LICENSE BY
PE-PAINTBALL.DE GMBH

LANGENBERGER STR. 9, TOR 5 & 6
40233 DÜSSELDORF
GERMANY

MADE IN CHINA

CONVERTING TO 50CAL

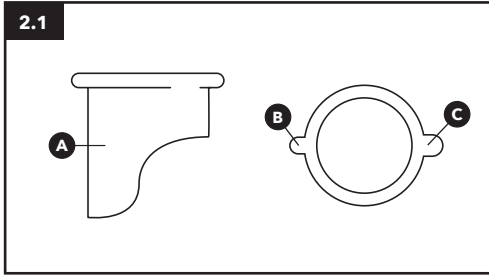

2.1 - THE 50 CAL INSERT IS A TUBE (A) AND TWO DIFFERENT SIZED TABS AT THE COLLAR (B & C).

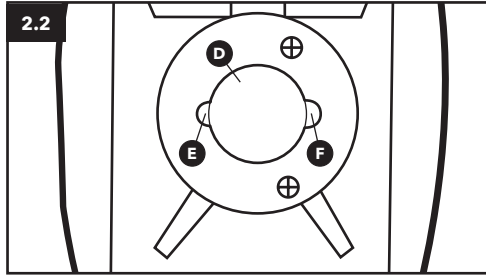

2.2 - FROM THE UNDERSIDE OF THE TRAY PUSH THE 50 CAL INSERT (TUBE FIRST) INTO THE OPENING (D) BEING SURE TO CORRECTLY ALIGN THE TABS (E & F).

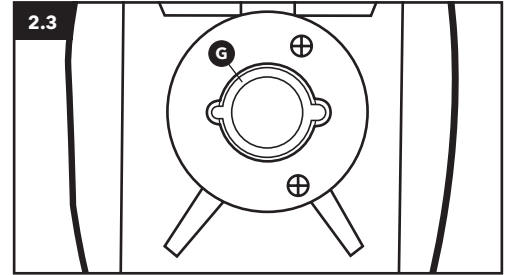

2.3 - ONCE INSTALLED, THE COLLAR (G) SHOULD SIT SECURELY AND FLUSH.
SEE 4.1 FOR LOADER REASSEMBLY.

INSTALLING THE ANTI-TAMPER BUTTON

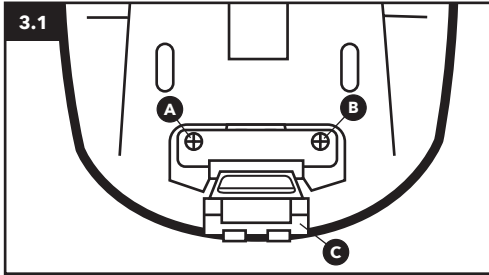

3.1 - IN THE LOWER SHELL, REMOVE THE SCREWS (A & B) AND REMOVE THE SHELL LATCH MECHANISM (C) TO EXPOSE THE STANDARD ON/OFF BUTTON.

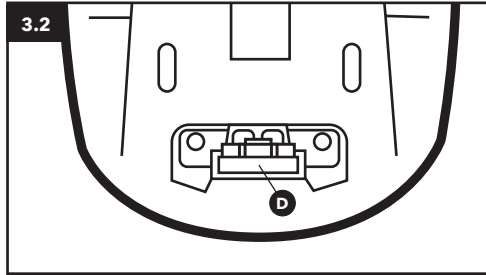

3.2 - REMOVE THE BUTTON (D) AND REPLACE WITH THE ANTI-TAMPER BUTTON (SEE 3.3). REPLACE THE LATCH MECHANISM AND SCREWS TO SECURE.
DO NOT OVER-TIGHTEN THE SCREWS.

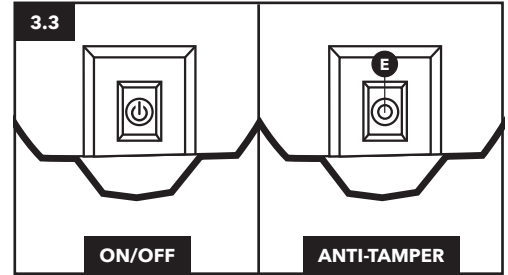

3.3 - THE ANTI-TAMPER LOCKS THE PUSH BUTTON ACTIVATION SO IT CAN ONLY BE SWITCHED ON/OFF VIA THE ACCESS HOLE (E).

REASSEMBLING THE SPEEDSTER LOADER

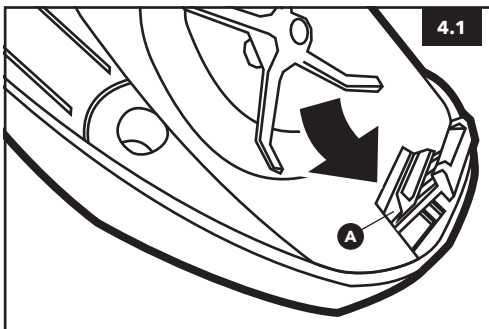

4.1 - HOOK THE BACK OF THE TRAY FIRMLY UNDER THE SHELL LOCK RIDGE (A) SO THAT IT WILL SECURELY PIVOT TOWARDS THE FRONT OF THE LOADER.

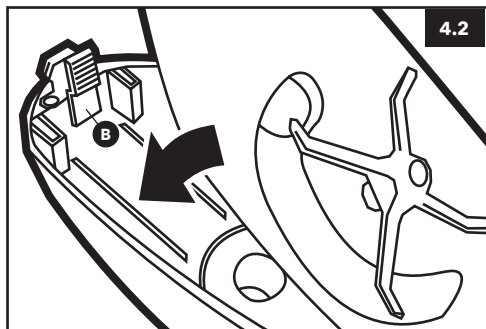

4.2 - PIVOT THE TRAY DOWNWARDS TOWARDS THE TRAY RELEASE LATCH AT THE FRONT (B).

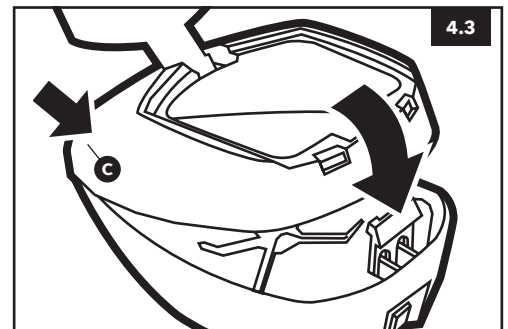

4.3 - HOOK THE FRONT OF THE UPPER SHELL INTO THE FRONT OF THE LOWER SHELL (C) THEN PIVOT BACKWARDS UNTIL THE SHELLS LOCK TOGETHER.

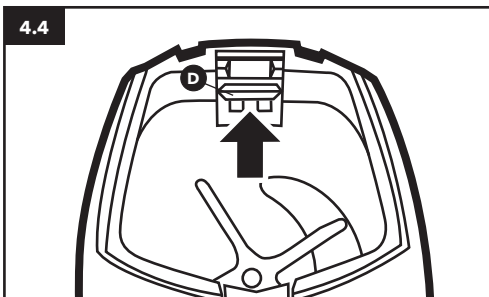

4.4 - LIFT THE UPPER SHELL LATCH (D) TOWARDS THE TOP TO LOCK THE SHELL HALVES.



4.5 - PIVOT THE LID (E) DOWNWARDS UNTIL IT FIRMLY CLICKS SHUT.

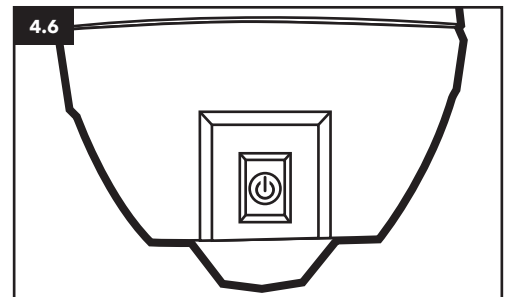

4.6 - SWITCH THE LOADER ON AND PLAY.