

# WORR MACHINE™



OWNER'S  
MANUAL



**WORR GAME PRODUCTS, LLC.  
WORR MACHINE® MARKER OWNERS MANUAL**



**WARNING:**

This is not a toy. Misuse may cause serious injury or death. Eye protection designed specifically for paintball must be worn by the user and persons within range. Recommend 18 years or older to purchase. 14 years old to use with adult supervision or 10 years old to use on paintball fields meeting ASTM-standard F1777-97. READ OPERATION MANUAL BEFORE USING.



**WARNING:**

Never shoot at anyone without proper protective equipment for eyes, ears, throat and head, which must be worn at all times. Eye protection must be designed specifically for paintball use. Failure to follow these safety precautions may result in bodily injury including blindness and deafness.

If you have a problem,  
DO NOT RETURN TO PLACE OF PURCHASE.  
Contact WGP for service.



**WORR GAME PRODUCTS, LLC.**  
252 Granite Street  
Corona, Ca 92879-1283  
Tel: (951) 520-9969  
TOLL FREE: (800) 755-5061  
[WWW.WORR.COM](http://WWW.WORR.COM)

© Copyright 2006 Worr Game Products, LLC. All rights reserved.

# WORR MACHINE® MARKER OWNERS MANUAL

**W**elcome to the world of the new Worr Machine, and thank you for your purchase of a new Worr Machine® marker. You will now be able to experience paintball at its highest level.

## **TABLE OF CONTENTS**

<b>I.</b>	Rules of Safe Paintball Marker Handling .....	<b>2</b>
<b>II.</b>	Preparing for Use .....	<b>4</b>
<b>III.</b>	Velocity .....	<b>7</b>
<b>IV.</b>	Worr Machine EG (Electronic) — E-Grip Operation .....	<b>8</b>
<b>V.</b>	Worr Machine EG (Electronic) — Mode Settings .....	<b>9</b>
<b>VI.</b>	Cleaning Your Marker .....	<b>14</b>
<b>VII.</b>	Troubleshooting .....	<b>15</b>
<b>VIII.</b>	F.A.Q.....	<b>16</b>
<b>VII.</b>	Warranty .....	<b>18</b>



## WORR MACHINE® MARKER OWNERS MANUAL

---

### I. RULES OF SAFE PAINTBALL MARKER HANDLING

**YOUR WORR MACHINE® MARKER IS NOT A TOY.**

18 years old to purchase. 14 years old to play with adult supervision or 10 years old to use on paintball fields meeting ASTM-standard F1777-97. Respect other peoples' property and when using the Worr Machine marker, obey all local, state and federal laws. When entering a paintball field, become aware of their rules and regulations. It is very important to have the proper paintball protection before going to the paintball field for play. This includes and is not limited to eye, head, throat, and body protection. All protection used should be designed for the sport of paintball, e.g.: eye gear designed specifically for paintball usage.

Always have a barrel plug or barrel sock in place and keep the safety ON when handling your marker. When repairing or cleaning your marker first remove barrel and gas cylinder, then depressurize your marker by pointing in safe direction and dry-firing. Always treat the paintball marker as if it were loaded. When handling the marker, always keep your fingers or any other objects away from the trigger assembly to avoid accidental discharges. Make sure when carrying or transporting the marker, to keep the muzzle pointed downward with a barrel blocking device in place. Before transporting your marker through public areas, such as airports, or bus and trains stations, call ahead for regulatory information regarding the carrying and transporting of such an item.

Remember, the Worr Machine marker should never be pointed or fired at anyone without the proper paintball approved eye and face protection, and should only be used at a supervised, licensed and insured paintball fields.

**NOTE:** A safe environment is an area where you and everyone within 200 yards is wearing paintball approved safety goggles and equipment. An area that is netted in and meets ASTM-standard F1777-97.



## I. RULES OF SAFE PAINTBALL MARKER HANDLING (CONT.)

- Treat every marker as if it were loaded.
- Never look down the barrel of a paintball marker.
- Keep your finger off the trigger until ready to shoot.
- Never shoot a person not wearing proper protection.
- Never point the marker at anything you don't wish to shoot, even if it is not loaded and there is no air source attached.
- Keep the marker on safe until ready to shoot.
- Keep the barrel blocking device in/on the marker when not shooting.
- Always remove paintballs and propellant source before disassembly.
- After removing propellant source, point marker in safe direction and discharge until marker is degassed.
- Store the marker unloaded and degassed in a secure place.
- Follow warnings listed on propellant source for handling and storage.
- Do not shoot at fragile objects such as windows.
- Every person within range must wear eye, face and ear protection designed specifically to stop paintballs.
- Always measure your marker's velocity before playing paintball and never shoot at velocities in excess of 300 feet per second.
- Never engage in vandalism.
- Do not modify your markers air system or regulators in any way.
- Do not use any paintball marker for drive-by shootings.
- Failure to follow these safety precautions may result in bodily injury including blindness and death.

### II. PREPARING FOR USAGE

1. Screw barrel onto marker
2. Place barrel blocking device properly onto the marker
3. Pull the cocking pin back until it latches into place
4. Make sure the safety is pushed to the "PUSH SAFE" position.
5. Connect the tank to the ASA (air system adapter.)

**NOTE:** Make sure to always get your tank filled by authorized, skilled and knowledgeable technicians for the correct fill limits of each tank. Do not try to refill tanks by yourself. Do not use tanks that have not been properly maintained or that are damaged. WGP recommends compressed air but CO2 will work. Always be sure to only use ASTM compliant tanks for your marker. Always use caution when refilling, attaching and handling any type of air tank.

6. Attach the loader to the feed port of the marker

**NOTE:** Use only 0.68 caliber paintballs in your Worr Game Products Worr Machine marker. All WGP Worr Machine markers are timed and tested prior to leaving the factory.

Before field use, ensure the velocity is in compliance with field safety guidelines. General field velocity limits are usually between 250-300 fps (feet per second). Your paintball markers velocity should never exceed 300 fps. Observe and abide by all local laws, regulations and field safety guidelines pertaining to the use of paintball markers.



#### **WARNING:**

Always wear paintball approved eye and face protection when dealing with a pressurized paintball marker.



**WARNING:**

**HIGH PRESSURE ALUMINUM ALLOY CYLINDER**  
**BOUTEILLE À HAUTE PRESSION EN ALLIAGE D'ALUMINIUM**  
**CILINDRO DE ALEACIÓN DE ALUMINIO PARA ALTA PRESIÓN**

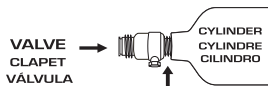

**⚠ DANGER ⚠ PÉRIL ⚠ PELIGRO**

The cylinder can fly off with enough force to kill if the valve unscrews from the cylinder.

- STOP if valve starts to unscrew from the cylinder. Screw it back on and take it to a trained person for repair.

**EXPLOSION HAZARD:** Improper use, filling, storage or disposal may result in property damage, serious personal injury, or death.

- This cylinder must be filled only by properly trained personnel in accordance with CGA Pamphlets P-1, C-6, G-6.3 and AV-7 available from the Compressed Gas Association, 4221 Walney Rd., Chantilly, Virginia 20151-2923.
- Valves must be installed and removed only by trained personnel.
- Do not overfill cylinder. Do not exceed the pressurized rating stamped on your cylinder.
- Do not expose to temperatures exceeding 130° F when pressurized.
- Do not use caustic cleaners or strippers.
- Do not modify this cylinder or valve in any way.
- Cylinder will be destroyed if exposed to fire or heated to a temperature exceeding 350° F.
- Keep cylinder out of reach of children.

## II. PREPARING FOR USAGE (CONT.)

**NOTE:** If you are using a CO2 tank, you need to be aware that CO2 has some limitations. If you play in a cold environment and you fire rapidly you may experience rapid fluctuations in velocity (shoot down) or you may experience “marker freeze up”. This is normal for CO2. CO2 is a liquid, and as you shoot the marker rapidly you are firing this liquid into the marker causing the marker to freeze up. The remedy for this problem is to allow the marker and tank to warm-up to room temperature. WGP suggests the use of compressed air when shooting rapidly or in cold weather.



### WARNING:

This is not a toy. Misuse may cause serious injury or death. Eye protection designed specifically for paintball must be worn by the user and persons within range. Recommend 18 years or older to purchase. 14 years old to use with adult supervision or 10 years old to use on paintball fields meeting ASTM-standard F1777-97. READ OPERATION MANUAL BEFORE USING.



### WARNING:

Never shoot at anyone without proper protective equipment for eyes, ears, throat and head, which must be worn at all times. Eye protection must be designed specifically for paintball use. Failure to follow these safety precautions may result in bodily injury including blindness and deafness.



## II. PREPARING FOR USAGE (CONT.)

- Paintball industry approved protective gear (for face and eyes) must be worn at all times while operating and performing adjustments on this marker.
- Prior to beginning any work on your marker, check to make sure that all excess pressure has been released by pointing the marker in a safe direction and pulling the trigger. This is a necessary precaution due to the fact that the marker may still contain pressure even after the removal of the gas source.
- Damages to the marker due to improper adjustments are NOT covered under warranty. If you are uncertain, unable or do not know how to perform work on the marker, have adjustments and repairs made by WGP.

## III. VELOCITY

- If using the Worr Machine EG (Electronic) Marker, consult mode selection instructions on the following page.
- To adjust the velocity, insert the velocity adjustment wrench provided with your marker into the screw at the rear of the marker. Turning the screw clockwise increases the markers velocity, turning it counterclockwise decreases the velocity.. Be sure to follow all local and ASTM standard rules when adjusting your velocity. Also make sure that you are always wearing paintball approved safety equipment when handling your marker.

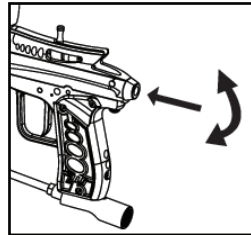

### WARNING:

WGP does not set the velocity prior to leaving the factory. You **MUST** set the velocity within field and safety limits using a chronograph prior to playing. Always use a chronograph to verify that your markers velocity does not exceed maximum safety limits.

## IV. WORR MACHINE EG (ELECTRONIC) — E-GRIP OPERATION

1. **Eye Protection:** Ensure all individuals within 200 yards are properly protected against paintball impacts.
2. **Engage Safety & Install Barrel Sleeve:** Push Safety from left to right on marker; Red Band around the safety should not be showing if the safety is on. Properly Install Barrel Sleeve.
3. **Install Battery:** Remove three allen screws and remove right side grip cover and properly install 9 volt battery.
4. **Test for Power:** To test for power press and hold down bottom button (below two lights on back of grip) for approximately 2 seconds. 2 Green lights should be illuminated. Reinstall grip cover (Do Not Over-Tighten Screws).
5. **Switching Between Modes:** Once the power is turned on, the marker will be in the initial setting of Semi-Automatic Mode (setting 1). This setting will be indicated by the bottom light turning **Green**. To switch to the 3 Round Burst Mode (setting 2) press the button once, the bottom light should turn **Amber**. You should now be in 3-Round Burst Mode. To switch to the Full-Auto Mode press the button once, the bottom light should turn **Red**. You should now be Full-Auto Mode. To switch back to the initial Semi-Auto Mode (setting 1) press the button once, the bottom light should turn **Green**. You should now be in the initial setting of Semi-Auto Mode (setting 1).

## V. WORR MACHINE EG (ELECTRONIC) — MODE SETTINGS

### SEMI-AUTO MODE



2 Green Lights Indicates  
Semi-Auto Mode

### 3-ROUND BURST MODE



Top Light Green,  
Bottom Light Amber  
Indicates 3-Round  
Burst Mode

### FULL-AUTO MODE



Top Light Green,  
Bottom Light Red  
Indicates Full-Auto Mode

**NOTE:** The top light should be green in all three modes. A low battery is indicated by the top light turning **Amber** or **Red**. When this occurs, replace the low battery with a new quality 9 volt battery or a quality rechargeable 9 volt battery.

The Electronic Anti-Chop Eye is in an Always On position and cannot be turned off.

# WORR MACHINE® MARKER OWNERS MANUAL



## WORR MACHINE

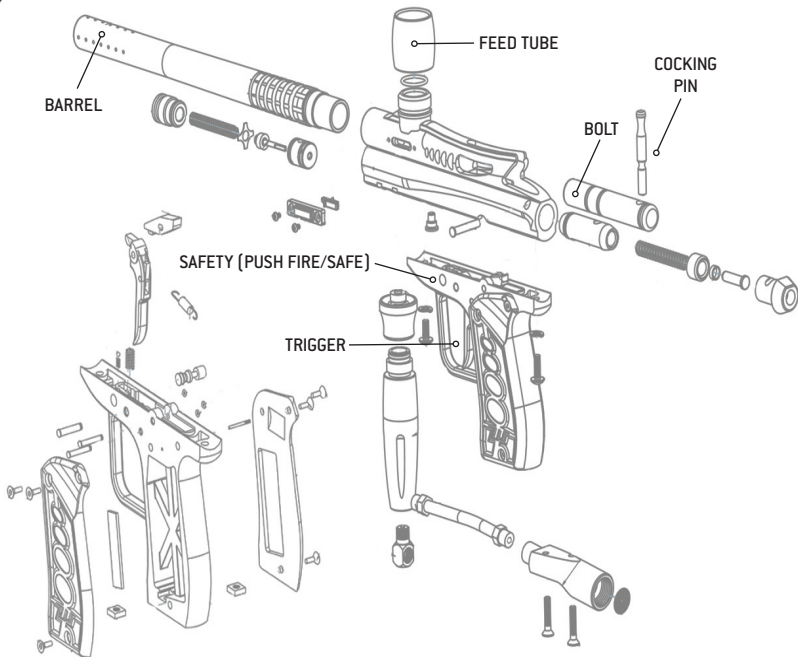

**WORR MACHINE RG (REGULATED)**

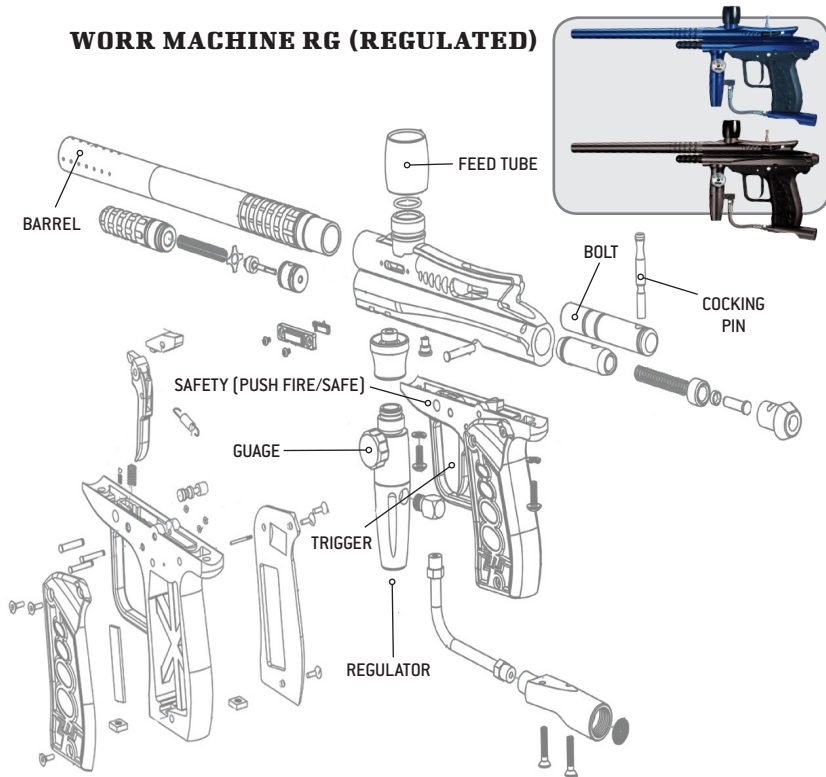



## WORR MACHINE AG (AIR ASSISTED)

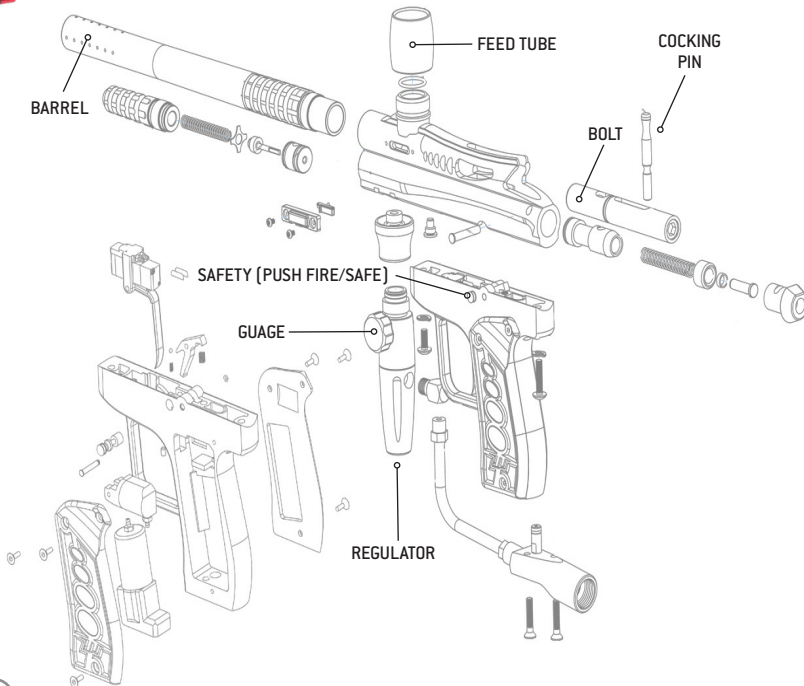

**WORR MACHINE EG (ELECTRONIC)**

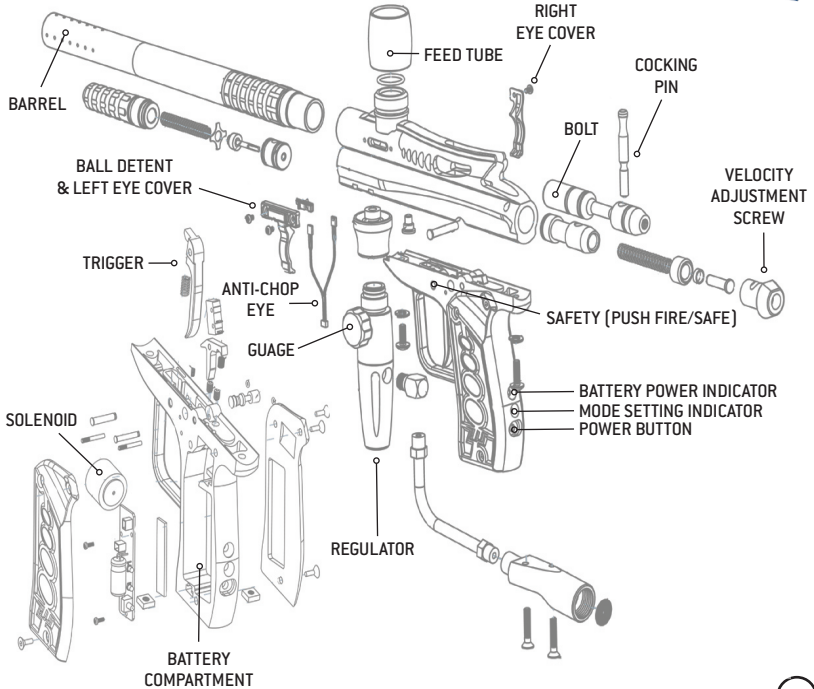

### VI. CLEANING YOUR MARKER

It isn't necessary to completely disassemble your marker to clean it. WGP recommends the following cleaning be done after each day of play:

1. Before you start ALWAYS make sure that all paintballs are out of the marker.
2. Remove air source and ensure that all air has been released from the marker.
3. Remove the barrel sock and then remove the barrel.
4. Lightly spray marker down with a 50-50 mix of rubbing alcohol and water and then wipe down.
5. Wipe down the marker with a clean cloth, or blow off the marker with compressed air (NOT CO2).
6. Remove bolt and lubricate bolt O-rings with Mineral oil, then reinstall.
7. Lubricate all moving parts with Mineral oil, and reassemble.
8. WGP recommends that after every 4-5 days of play you place 3-4 drops of 3 in 1 or other paintball marker specific oil in the air receiver and fire the marker 10-15 times without the barrel. This will distribute the oil throughout the marker and lubricate the internals.

#### Factory Approved Lubricants:

- Mineral oil only



#### **WARNING:**

Always make sure you and everyone around you wears protection when you clean the marker or check it for paintballs.



## VII. TROUBLESHOOTING

**NOTE:** Prior to beginning any work on your marker, check to make sure that all excess pressure has been released by pointing the marker in a safe direction and pulling the trigger. This is a necessary precaution due to the fact that the marker may still contain pressure even after the removal of the gas source.

1. Gas leaks from the tank connection.

- Check and or replace tank o-ring.

2. Gas leaks from inside barrel.

- Try firing the marker a few times in a safe enviroment.
- Valve seal may be damaged, repace valve stem assembly.



3. Marker fails to fire.

- Cock the marker and try again.
- Make sure the tank has gas/air in it, and be sure it is screwed all the way on to the marker.
- Safely check for broken paint shells in chamber, lubricate all moving parts.

4. Marker fails to recock.

- Check and/or replace striker o-ring.
- Make sure the tank has gas/air in it, and be sure it is screwed all the way on to the marker.

5. Marker rapid fires or mechanism sticks or hangs up.

- Broken paintball shell stuck inside, clean the mechanism.
- Lack of lubricant, lubricate striker and bolt.

### VIII. F.A.Q.

**Q)** How do I safely maintain my WGP Worr Machine® marker?

---

**A)** Safely maintaining your marker is simple and easy. You need only to clean and oil your marker to keep it up and running.

**Q)** How do I oil my marker?

---

**A)** You only need to lubricate your marker after every 4 to 5 days of play. To oil your marker you first remove your loader, then fire all excess paintballs out of the marker. Next remove your tank and fire all excess air from the marker. Now remove your barrel. Next drop 3 to 4 drops of approved paintball marker oil into the air receiver and safely fire the marker 10-15 times. This will distribute the oil throughout the internals of the marker. At this time you can also lubricate your bolt O-rings and your striker. Be sure that the hole in between the 2 O-rings on your bolt is always facing down. Factory approved lubricants: Mineral oil.

**Q)** How do I safely clean my marker?

---

**A)** To clean your marker you first find a safe environment then remove your loader, then fire all excess paintballs out of the marker. Next remove your tank and fire all excess air from the marker. Now remove your barrel, then lightly spray down marker with water and then wipe it down with a clean cloth.

**Q)** Does WGP recommend CO2 or compressed air on my marker?

---

**A)** WGP recommends compressed air, but the markers will also work on CO2. If you are using a CO2 tank, you may experience the marker getting cold, this is normal for CO2. CO2 consists of frozen liquid and when this liquid enters the marker it will cause the marker to get cold. To remedy this problem, let your marker warm up to room temperature in a safe, secure place.

## VIII. F.A.Q. (CONT.)

**Q)** My marker is shooting when I air it up, what do I do?

**A)** Before you air up your marker always be sure to cock the marker first, then fire your marker. It is not recommended to adjust or remove the internals without proper training.

**Q)** I broke a paintball in my marker. How do I clean it?

**A)** To clean broken paintball out of your marker you will first remove your loader, next your tank be sure to fire all excess paintballs and air from your marker. Next remove your barrel and then your bolt. Using a squeegee or battle swab, run it through the same chamber you pulled the bolt from, then run it through the barrel. Reinstall the bolt. Be sure that the hole in between the 2 o-rings on your bolt between the 2 o-rings is facing down and your ready to go.

**Q)** I've removed my bolt and replaced it, and my velocity has dropped. What is the problem?

**A)** Any time you remove the bolt from your marker, you must always be sure that the hole in between the 2 O-rings on your bolt is always facing down before reinstallation. This is common problem that could directly effect the velocity of your marker.

**Q)** What is the reason to have different barrel sizes?

**A)** The reason for using different barrel sizes is, paintballs are different sizes due to freshness, weather and other factors. By having different barrel sizes your are able to match your paint to your barrel to get the best accuracy and consistency out of your marker.

**Q)** I have a question that is not on this list. What do I do?

**A)** If you have more questions and did not find the answers here, Please contact WGP directly at 800-755-5061. Or visit [www.worr.com](http://www.worr.com).

## IX. ONE YEAR LIMITED WARRANTY

Worr Game Products®, LLC. warrants that your Worr Machine marker will be free from defects in materials and workmanship for one year from purchase date.

Any product determined by WGP to be defective in materials or workmanship in accordance with the above warranty will be repaired or replaced, at the option of WGP, free of charge when received at the factory freight prepaid, together with proof of purchase.

This warranty is expressly in lieu of all other warranties. Any implied warranties of merchantability or fitness for a particular purpose are limited to the same duration as this express warranty.

This warranty does not cover incidental or consequential damages. WGP shall not be liable for any incidental or consequential damages. Some states do not allow the exclusion or limitation of implied warranties, incidental or consequential damages, so the above limitations and exclusions may not apply to you.

This warranty does not cover any problem resulting from misuse, abuse, neglect, alteration, failure to perform maintenance as instructed, unauthorized repair or service, or damage caused by contaminants.

This warranty does not cover any representation or warranty made by Dealers beyond the provisions of this warranty. Non warranty repairs may incur a repair charge.

This warranty does not cover costs incurred for normal repair, inspection and preventive maintenance.

You must establish proof of purchase to obtain warranty service or replacement. You may establish proof of purchase by completing the Warranty Registration Card and mailing it to WGP.

This warranty gives you specific legal rights, and you also have other rights which vary from state to state. If you have any questions about your WGP product, please call us toll free at 1-800-755-5061.

Warranty Service is available by sending your marker to:

**Worr Game Products LLC.**  
Attn: WARRANTY SERVICE  
252 Granite St. Corona, CA 92879  
P: 951-520-9969 F: 951-520-9699  
[www.worr.com](http://www.worr.com)

**IMPORTANT:** You must call Worr Game Products LLC. to request an RMA number before sending your WGP marker in for warranty or tech services.

**WORR MACHINE® MARKER OWNERS MANUAL**

**ATTENTION WARRANTY SERVICE**

Worr Game Products LLC.  
Warranty Registration Card

**Please fill out this warranty card and mail with a photocopy of your purchase receipt to WGP. Thank You.**

Worr Machine Serial # \_\_\_\_\_  
Name \_\_\_\_\_  
Address \_\_\_\_\_  
City \_\_\_\_\_  
State \_\_\_\_\_ Zip Code \_\_\_\_\_ Country \_\_\_\_\_  
Phone \_\_\_\_\_ E-mail \_\_\_\_\_  
Purchased Date \_\_\_\_\_  
Purchased From \_\_\_\_\_  
 Pro Shop  Internet  Field  Sporting Goods  Other

How much did you pay for your Worr Machine®? \_\_\_\_\_  
Where did you hear about Worr Machine®? \_\_\_\_\_  
What paintball marker did shoot prior to this Worr Machine®? \_\_\_\_\_  
How many years have you been playing paintball? \_\_\_\_\_  
What type of paintball do you play? \_\_\_\_\_  
What made you choose a WGP marker? \_\_\_\_\_  
What paintball magazines do you read? \_\_\_\_\_  
What model of Worr Machine® did you purchase? \_\_\_\_\_  
What paintball magazines do you read? \_\_\_\_\_  
What made you choose a WGP Worr Machine®? \_\_\_\_\_  
What paintball magazines do you read? \_\_\_\_\_

**PLEASE MAIL YOUR CARD IMMEDIATELY.**



**WORR GAME PRODUCTS LLC.**

252 Granite Street  
Corona, CA 92879  
U.S.A.

Phone: 909.520.9969  
Fax: 909.520.9699  
[www.worr.com](http://www.worr.com)

P/N 142222-000